

**SPLIT TYPE
ROOM AIR CONDITIONER
WALL MOUNTED type**

SERVICE MANUAL



Models

Indoor unit	Outdoor unit
ASU30CLX	AOU30CLX
ASU36CLX	AOU36CLX

CONTENTS

SPECIFICATIONS	1
DIMENSIONS	2
REFRIGERANT SYSTEM DIAGRAM	4
CIRCUIT DIAGRAM	5
INDOOR PCB CIRCUIT DIAGRAM	6
OUTDOOR PCB CIRCUIT DIAGRAM ...	9
ERROR CONTENTS	14
DISASSEMBLY ILLUSTRATION	15
PARTS LIST	23
STANDARD ACCESSORIES	25

SPECIFICATIONS

INDOOR UNIT	ASU30CLX	ASU36CLX
OUTDOOR UNIT	AOU30CLX	AOU36CLX
COOLING CAPACITY	30,700 BTU/hr	33,100 BTU/hr

ELECTRICAL DATA

POWER SOURCE	208 V / 230 V	208 V / 230 V
FREQUENCY	60 Hz	60 Hz
RUNNING CURRENT	15.2 A	17.7 A
INPUT WATTS	3,460 W	4,040 W
SEER	15.0	15.0
MOISTURE REMOVAL	9.7 Pts/hr (4.6 L/hr)	10.1 Pts/hr (4.8 L/hr)
AIR CIRCULATION HIGH	647 cfm (1,100 m ³ /hr)	706 cfm (1,200 m ³ /hr)

COMPRESSOR

TYPE	Hermetic motor compressor, 4 poles, Rotary type	
DISCRIMINATION	5KD240XAD21	
POWER SOURCE	208 V / 230 V 60Hz	
REFRIGERANT	R-410A	4 lb.10 oz (2,100 g)

FAN MOTOR

POWER SOURCE		208 V / 230 V	208 V / 230 V
INDOOR UNIT	HIGH	1,330 r.p.m.	1,430 r.p.m.
	MED	1,120 r.p.m.	1,120 r.p.m.
	LOW	940 r.p.m.	940 r.p.m.
	QUIET	830 r.p.m.	830 r.p.m.
OUTDOOR UNIT		850 r.p.m.	850 r.p.m.

DIMENSIONS

INDOOR UNIT	H x W x D	12-5/8 x 39-1/4 x 9 inch
		320 x 998 x 228 mm
OUTDOOR UNIT	H x W x D	32-3/4 x 35-3/8 x 13 inch
		830 x 900 x 300 mm

WEIGHT

INDOOR UNIT	Gross / Net	40 / 31 lbs. (18 / 14 kg)	
OUTDOOR UNIT	Gross / Net	155 / 137 lbs. (70 / 62 kg)	155 / 137 lbs. (70 / 62 kg)

NOISE LEVEL

INDOOR UNIT	HIGH	47 dB	49 dB
	MED	41 dB	41 dB
	LOW	36 dB	36 dB
	QUIET	32 dB	32 dB
OUTDOOR UNIT		53 dB	54 dB

OUTLINE AND DIMENSIONS

Unit : inch (mm)

INDOOR UNIT

Models : ASU30CLX, ASU36CLX

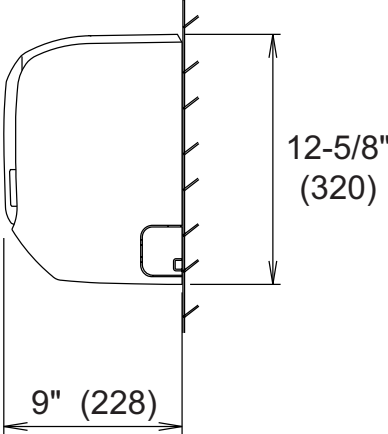
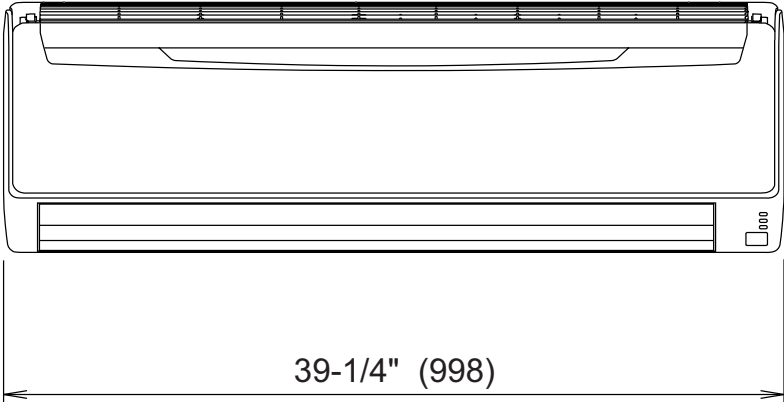

OUTDOOR UNIT

Models : AOU30CLX, AOU36CLX

Unit : inch (mm)

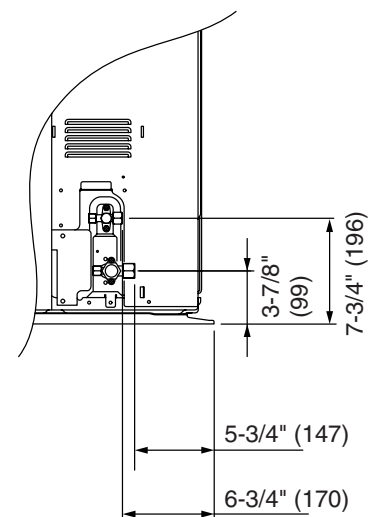
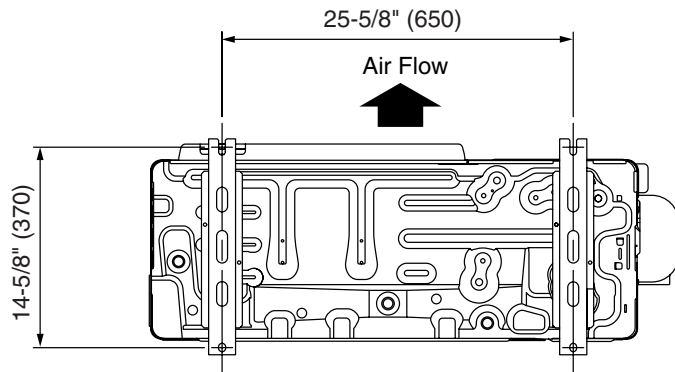
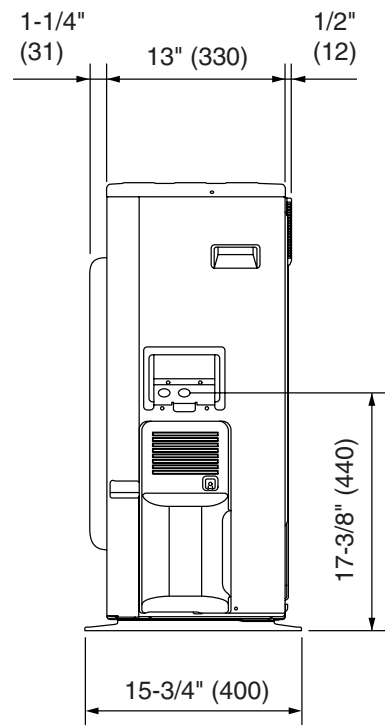
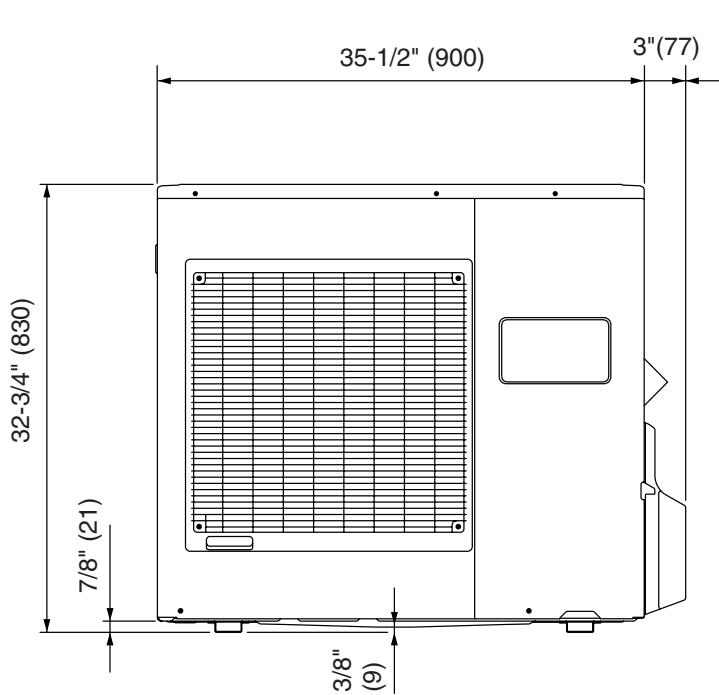
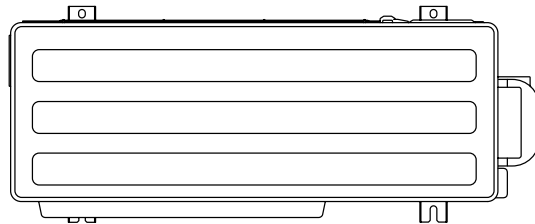

REFRIGERANT SYSTEM DIAGRAM

Models : ASU30CLX / AOU30CLX
ASU36CLX / AOU36CLX

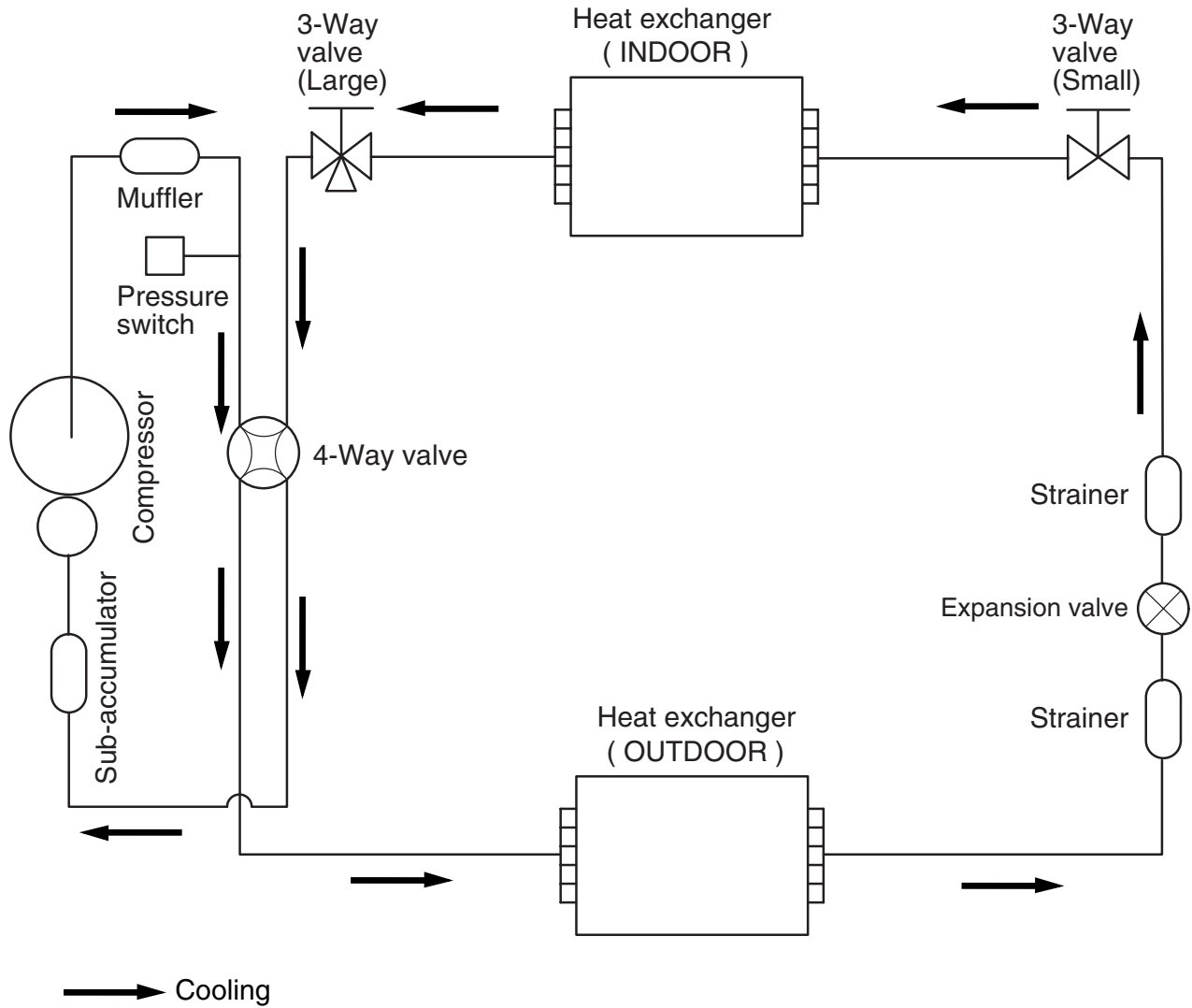

Refrigerant pipe diameter
Liquid : 3/8" (9.52 mm)
Gas : 5/8" (15.88 mm)

CIRCUIT DIAGRAM

INDOOR UNIT

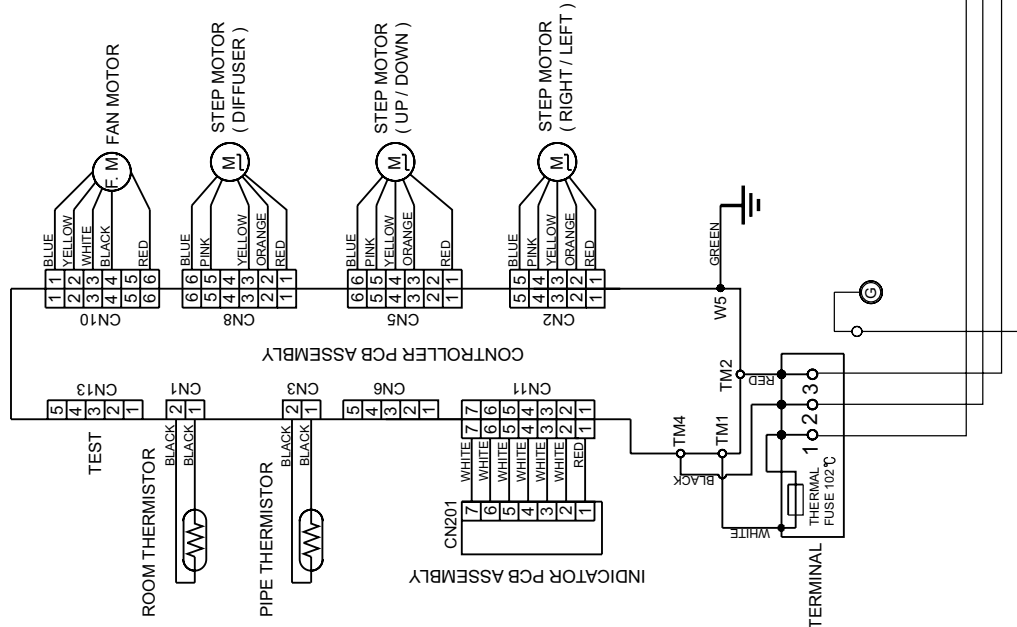

OUTDOOR UNIT

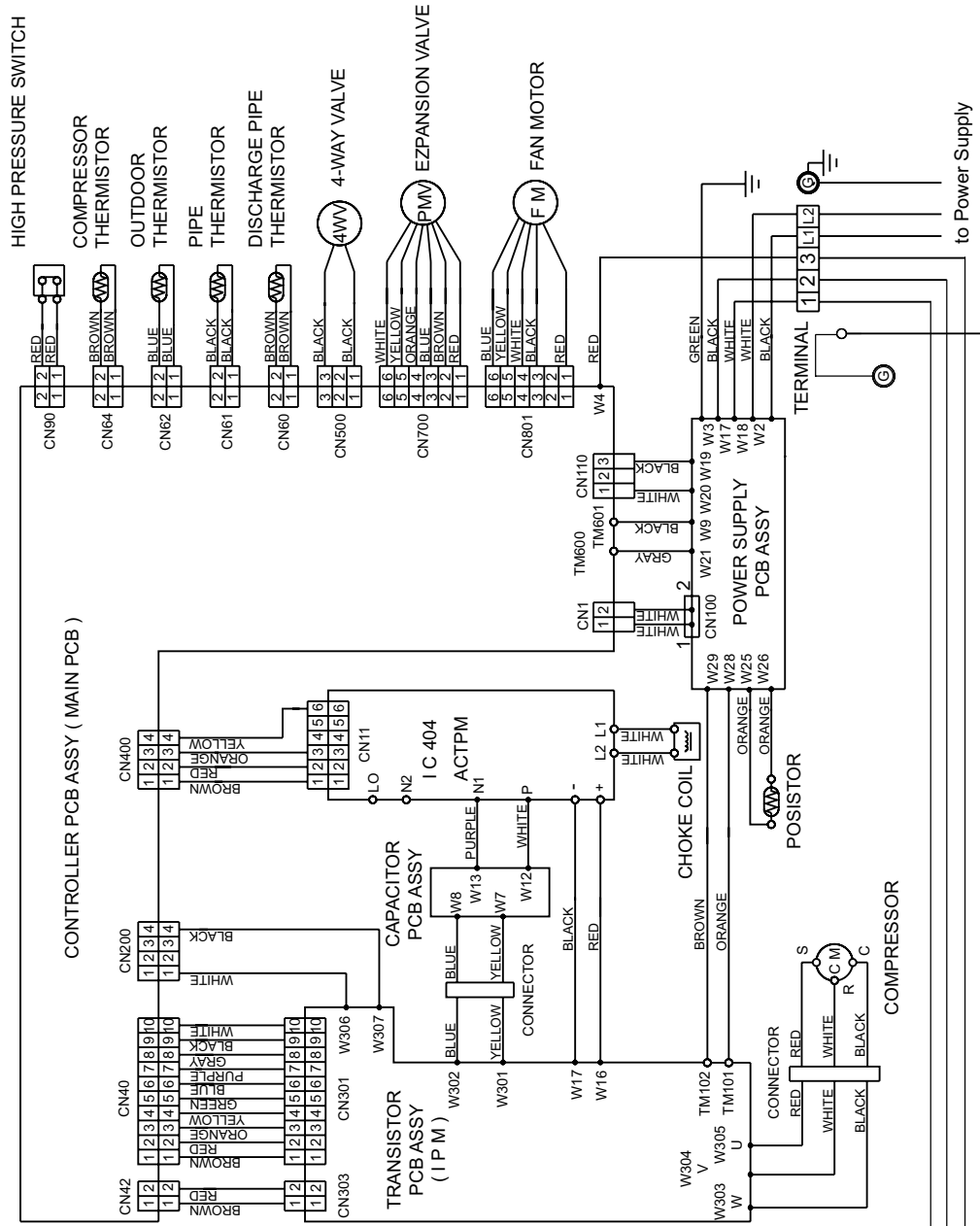

INDOOR PCB CIRCUIT DIAGRAM

Models :
ASU30CLX
ASU36CLX

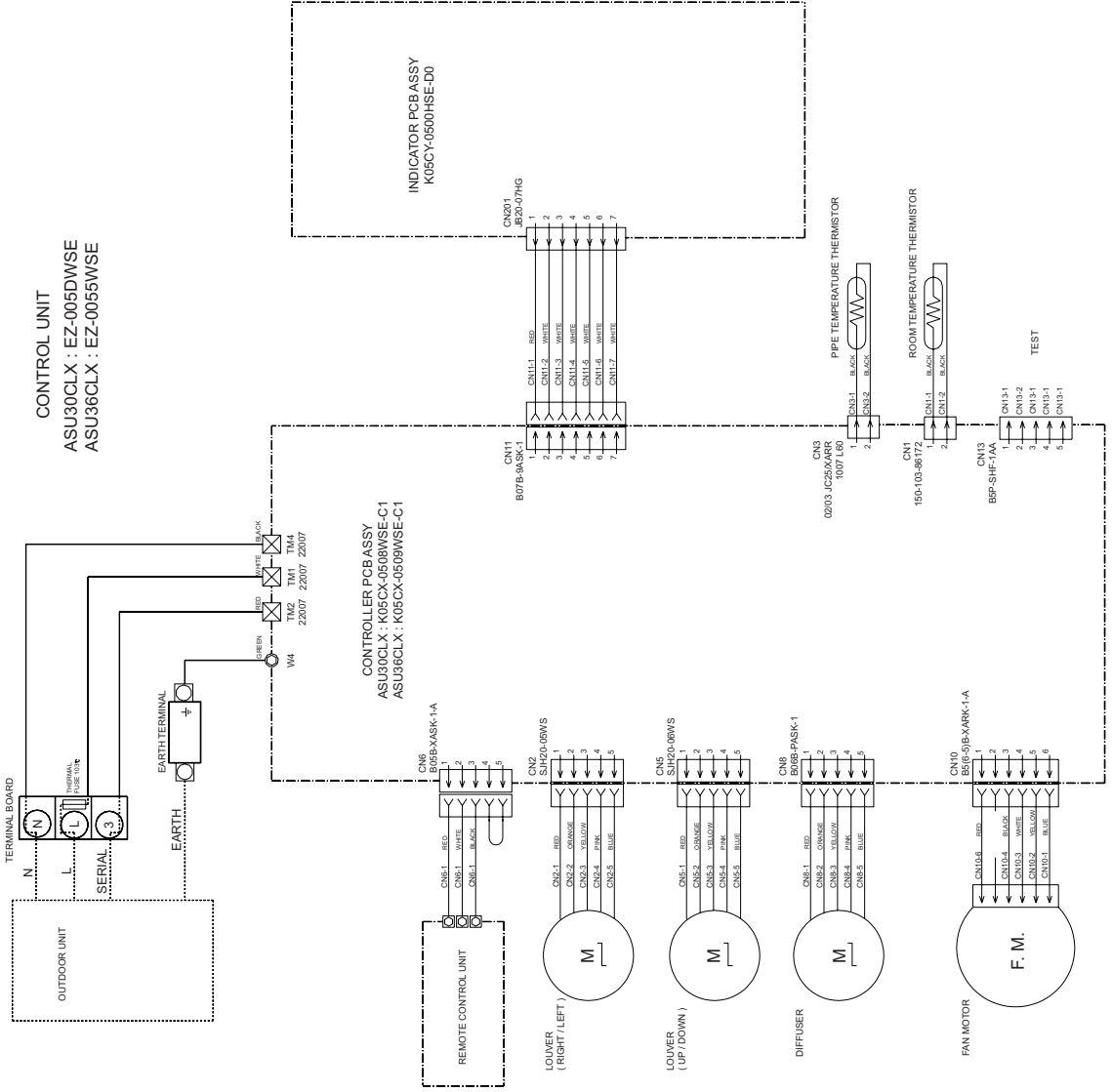

CONTROLLER PCB ASSY
 ASU30CLX : K05CX-0508WSE-C1
 ASU36CLX : K05CX-0509WSE-C1

Models : ASU30CLX
 ASU36CLX

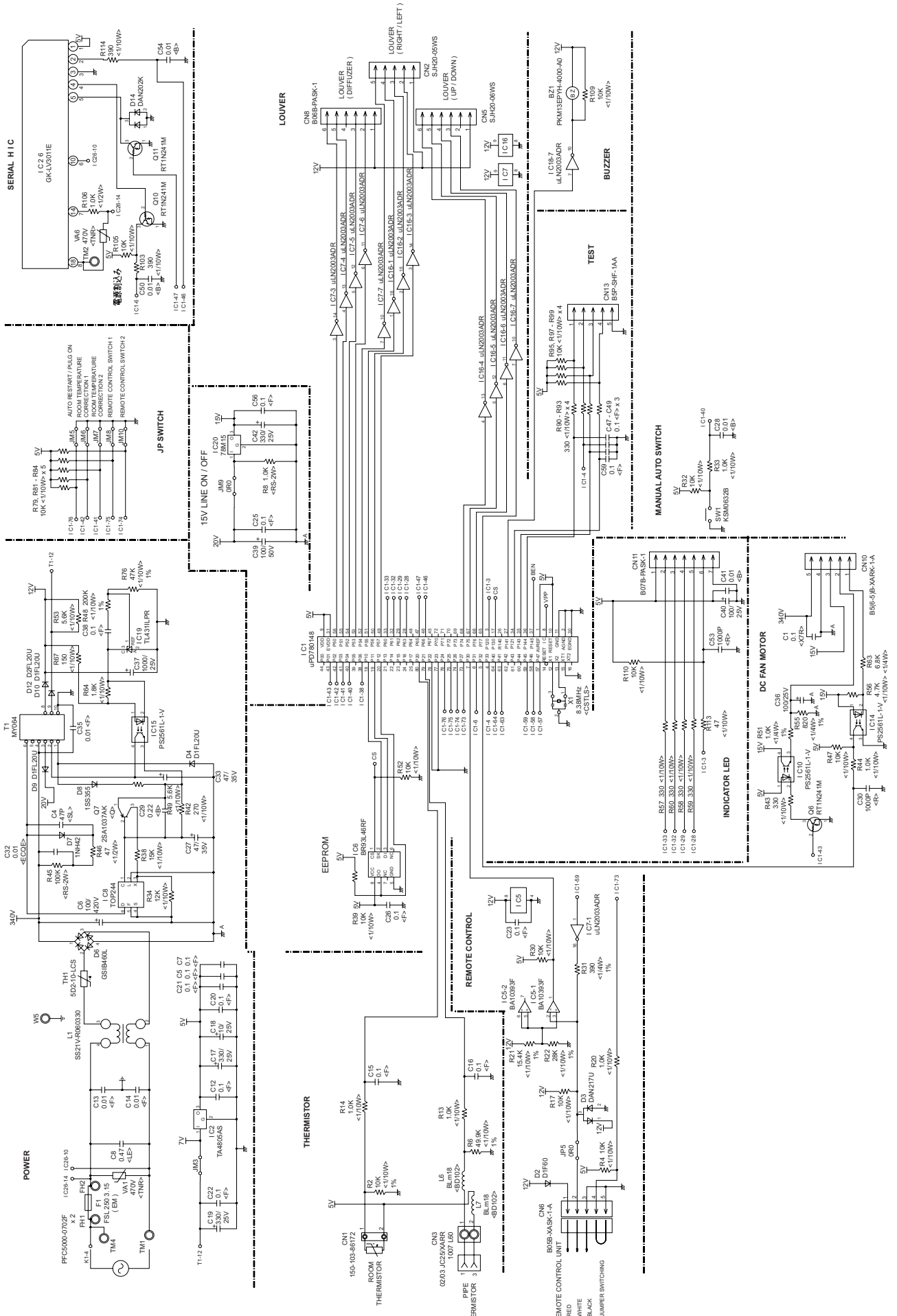

Models : ASU30CLX
ASU36CLX

INDICATOR PCB ASSY K05CY-0500HSE-D0

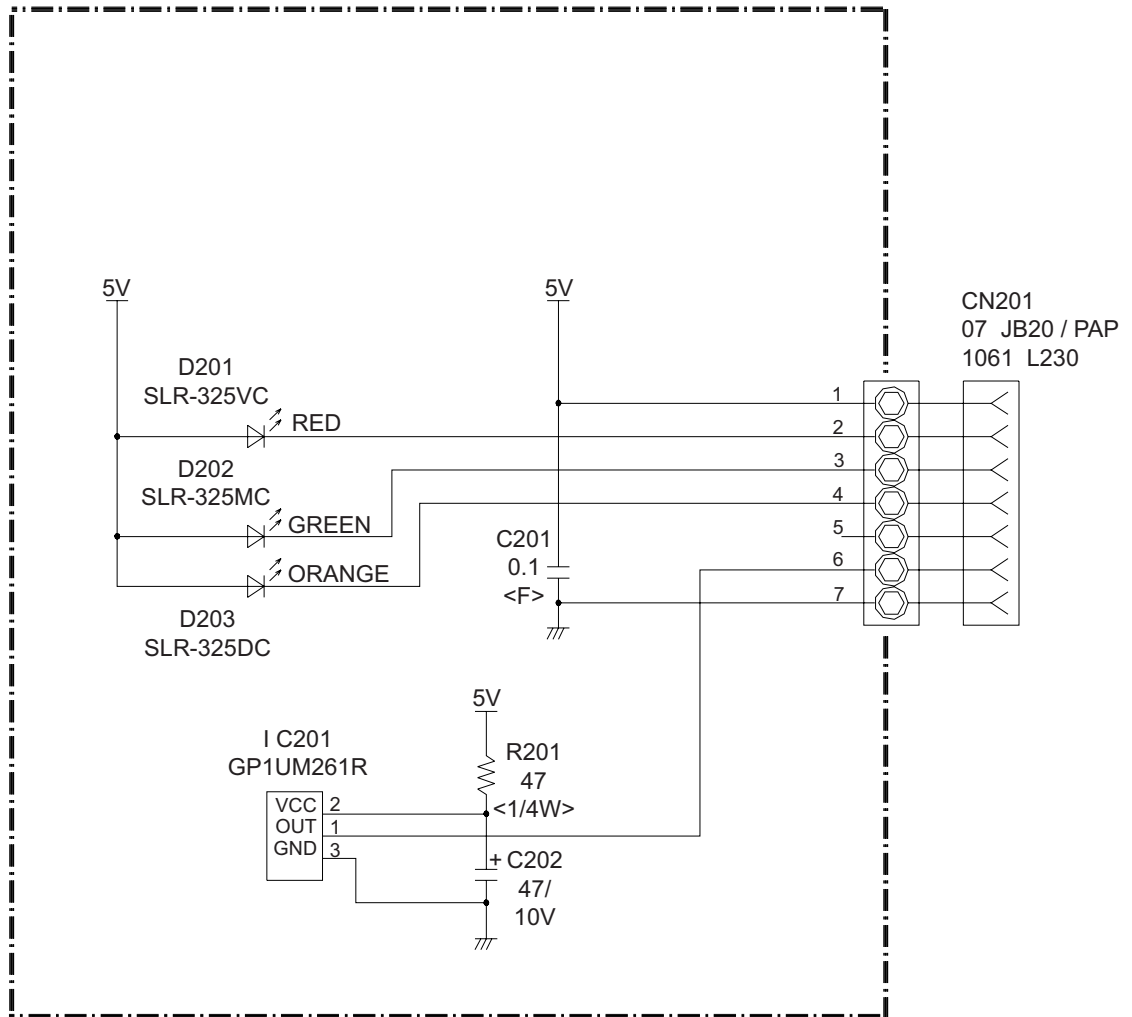

Models : AOU30CLX
AOU36CLX

POWER SUPPLY PCB
K05CW-0503HUE-FL0

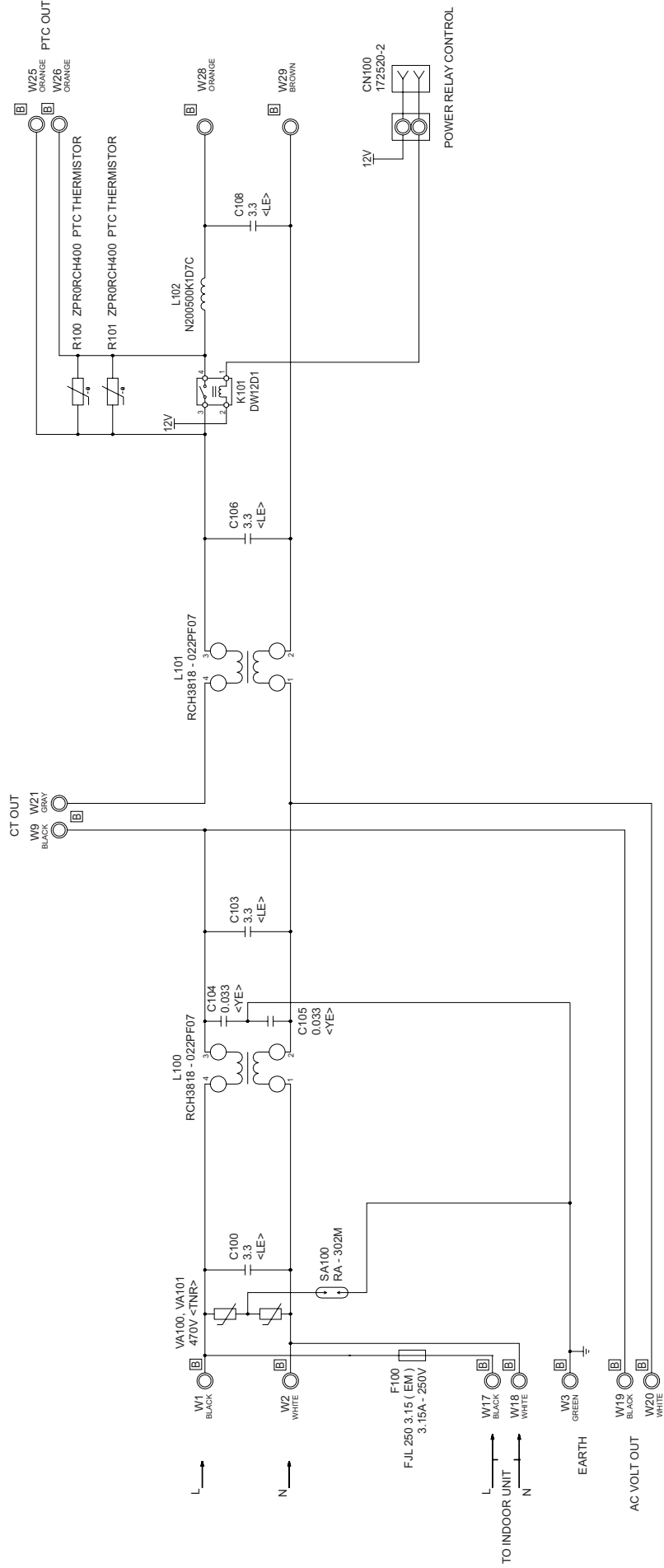

Models : AOU30CLX
AOU36CLX

CAPACITOR PCB ASSEMBLY K05FB-0500HUE-P0

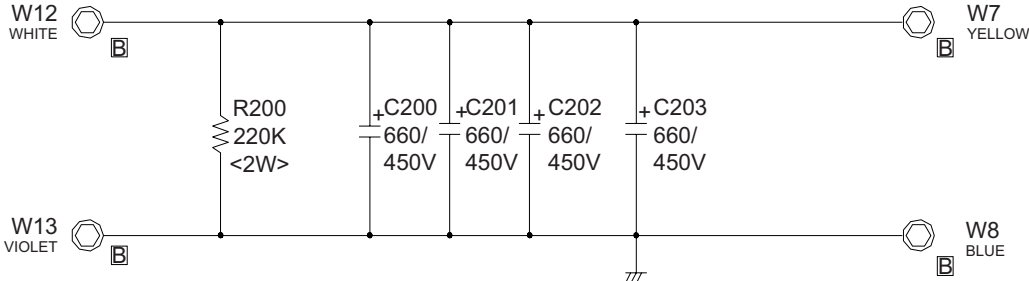

ERROR CONTENTS

Error	Display		Error
	Operation LED	Timer LED	
Serial signal error	Normal	2 flash	Serial signal (reverse) error, at operation start up
		3 flash	Serial signal (reverse) error, during operation
		4 flash	Serial signal (forward) error, at operation start up
		5 flash	Serial signal (forward) error, during operation
		8 flash	Wired remote controller error
Indoor unit thermistor error	2 flash	2 flash	Indoor temperature thermistor open / short
		3 flash	Heat exchanger middle thermistor open / short
Outdoor unit thermistor error	3 flash	2 flash	Discharge thermistor open / short
		3 flash	Heat exchanger thermistor open
		4 flash	Outdoor temperature thermistor open / short
		8 flash	Compressor temperature thermistor open / short
Indoor unit control error	4 flash	2 flash	Forced automatic SW welded
		3 flash	Main relay welded
		4 flash	Power interruption error
		7 flash	VDD permanent stop protection
		8 flash	reverse VDD permanent stop protection
Outdoor unit control error	5 flash	2 flash	Current trip error
		3 flash	CT abnormal
		5 flash	Compressor location detection error
		6 flash	Outdoor unit fan drive system abnormal
Indoor fan motor error	6 flash	2 flash	Abnormal lock
		3 flash	Abnormal rotation
Refrigerant cycle error	7 flash	2 flash	Discharge Temperature abnormal
		3 flash	Cooling high pressure abnormal rise
		5 flash	Pressure switch trouble
Optional function error	8 flash	2 flash	Active filter voltage trouble (second time)
		3 flash	Active filter voltage trouble (first time)
		4 flash	PFC circuit error
Model information error	0.1 sec on/off	0.1 sec on/off	Model information error

DISASSEMBLY ILLUSTRATION

Models : ASU30CLX , ASU36CLX

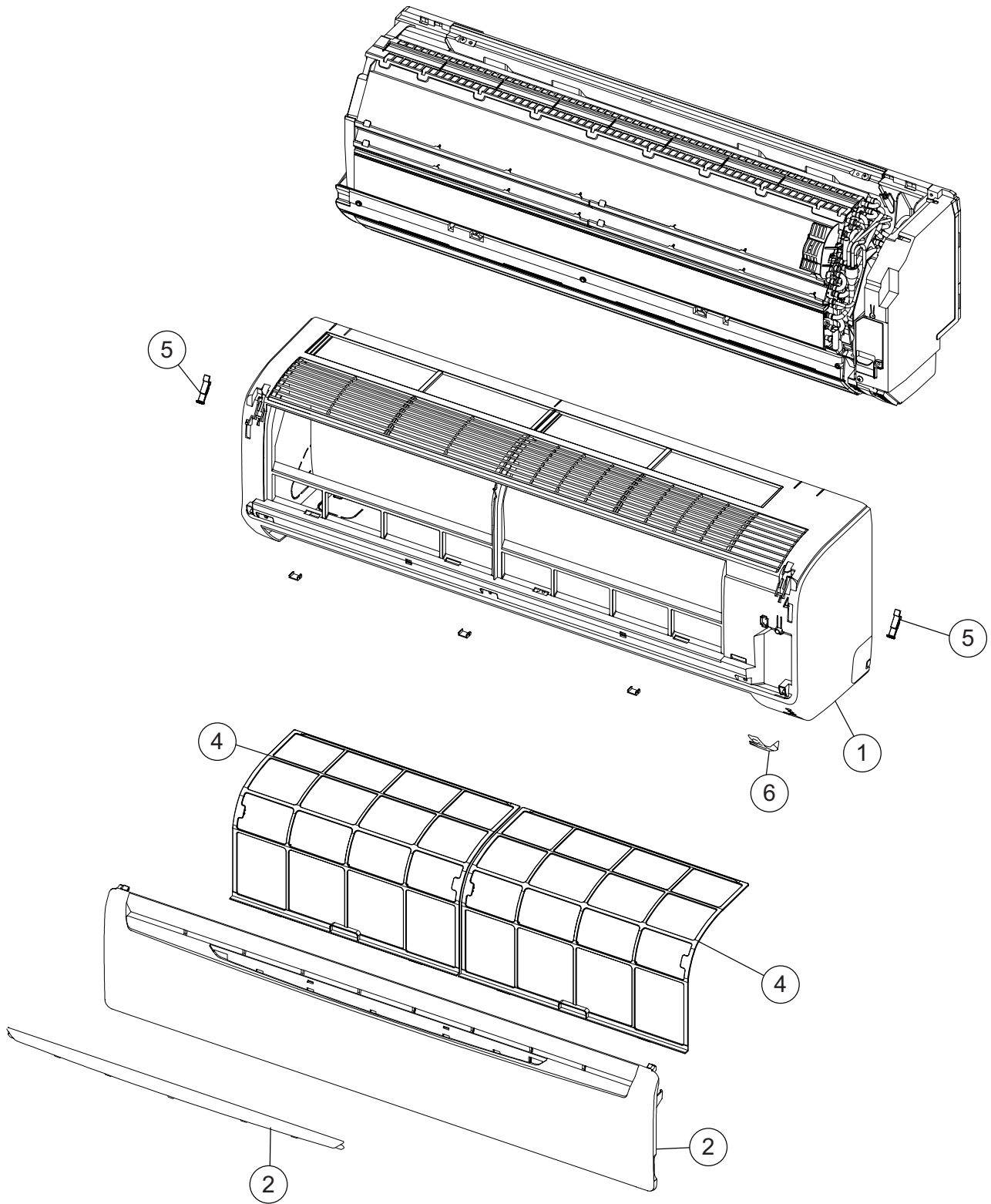

Models : ASU30CLX, ASU36CLX

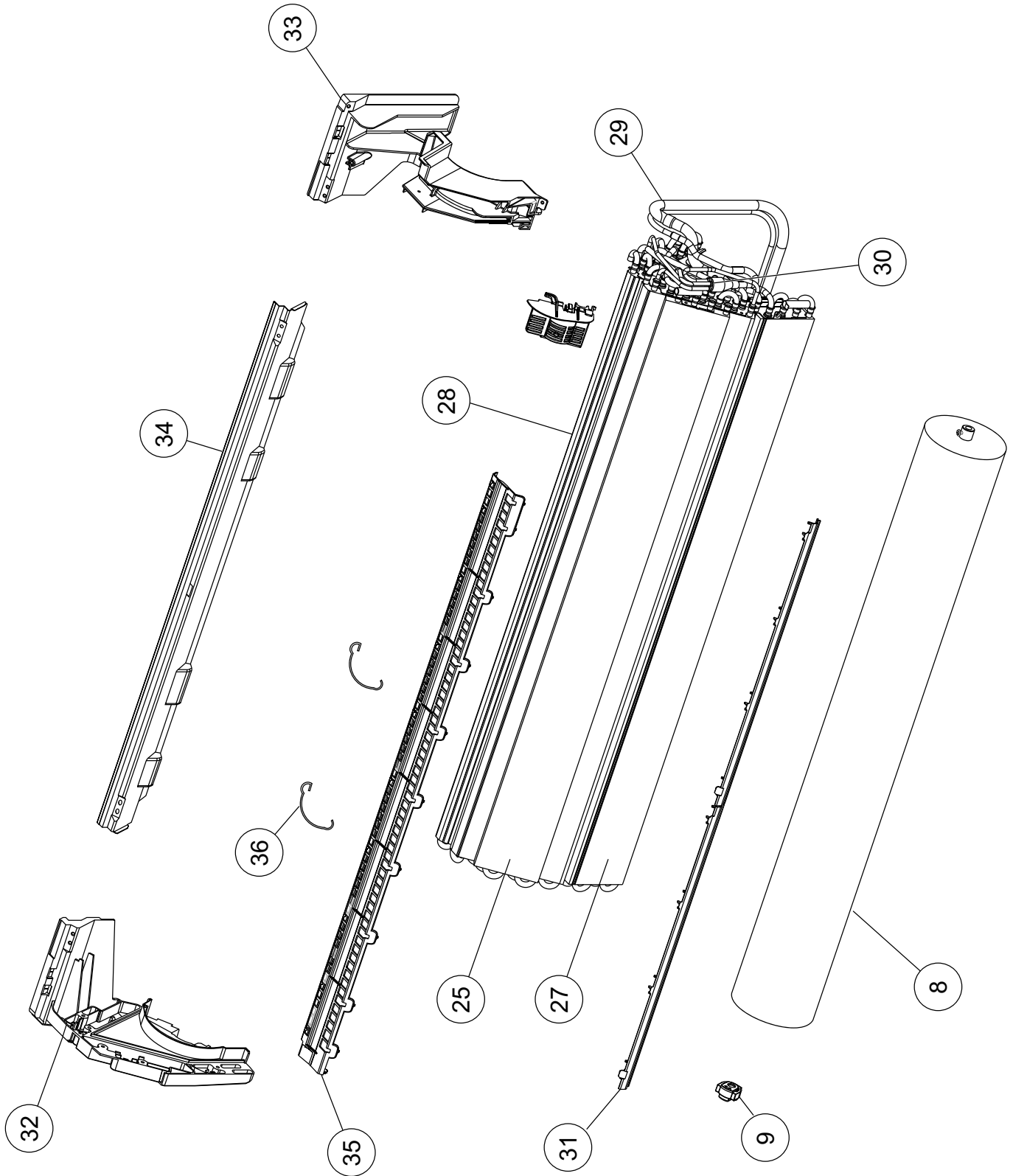

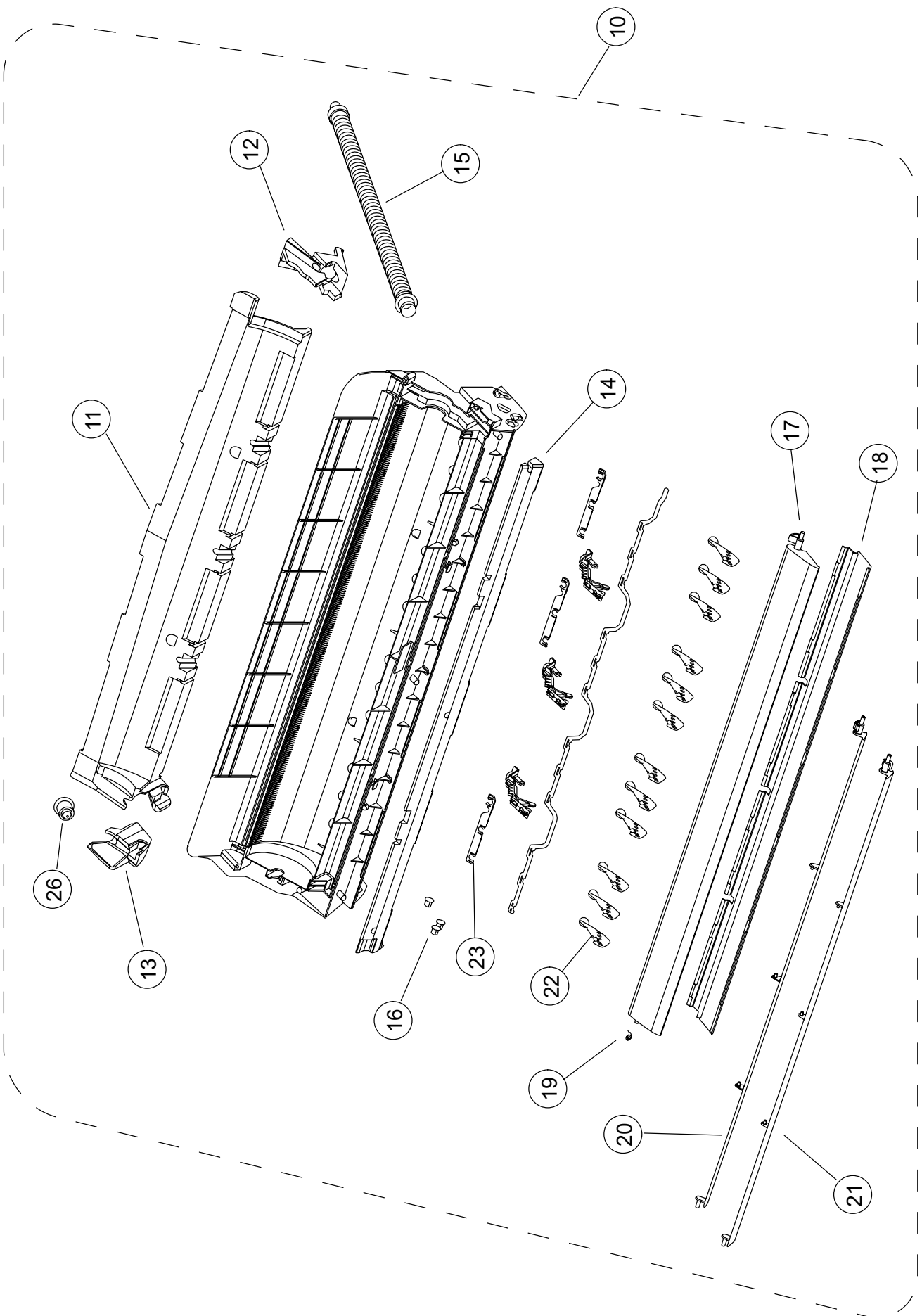

Models : ASU30CLX, ASU36CLX

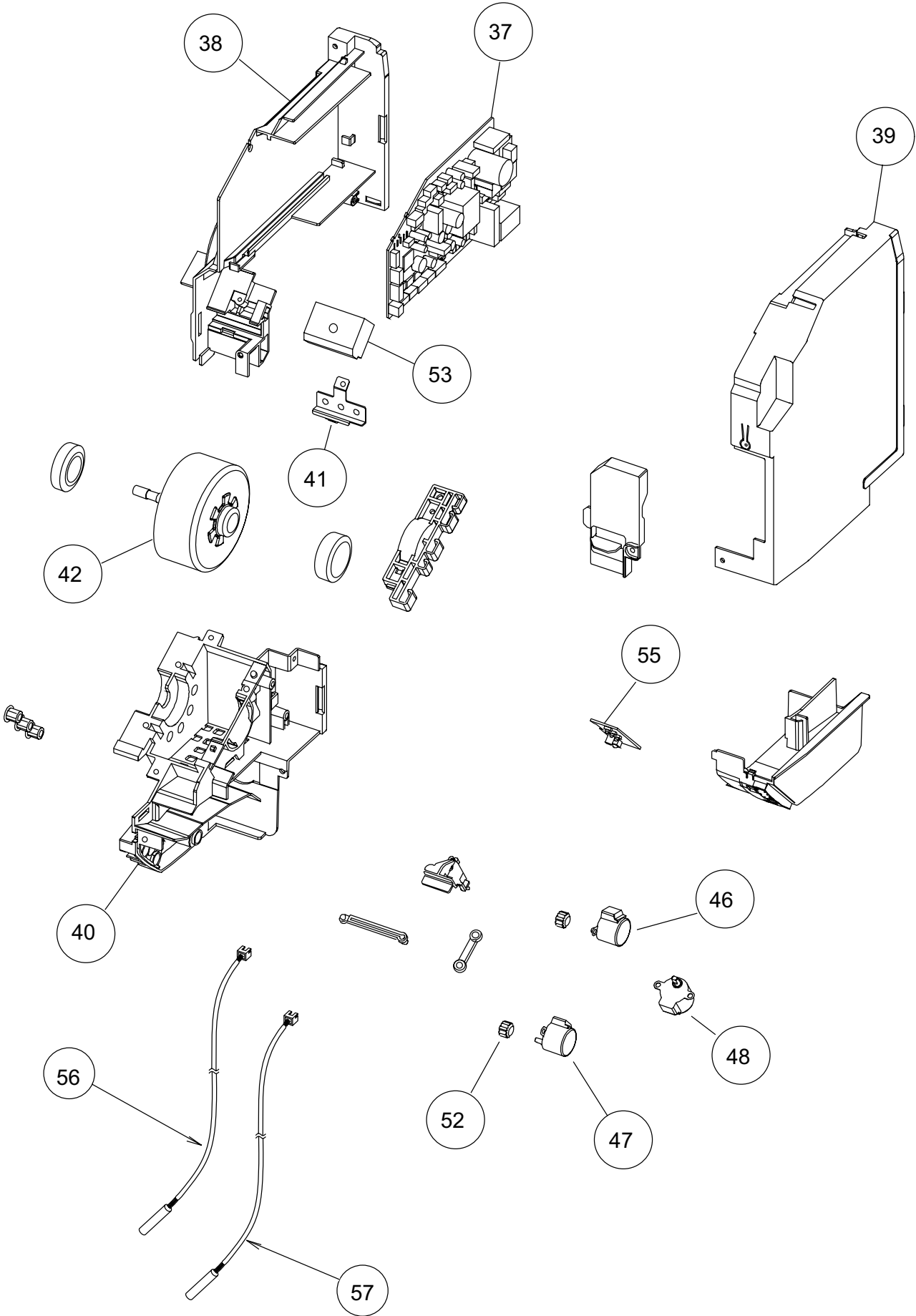

Models :
AOU30CLX
AOU36CLX

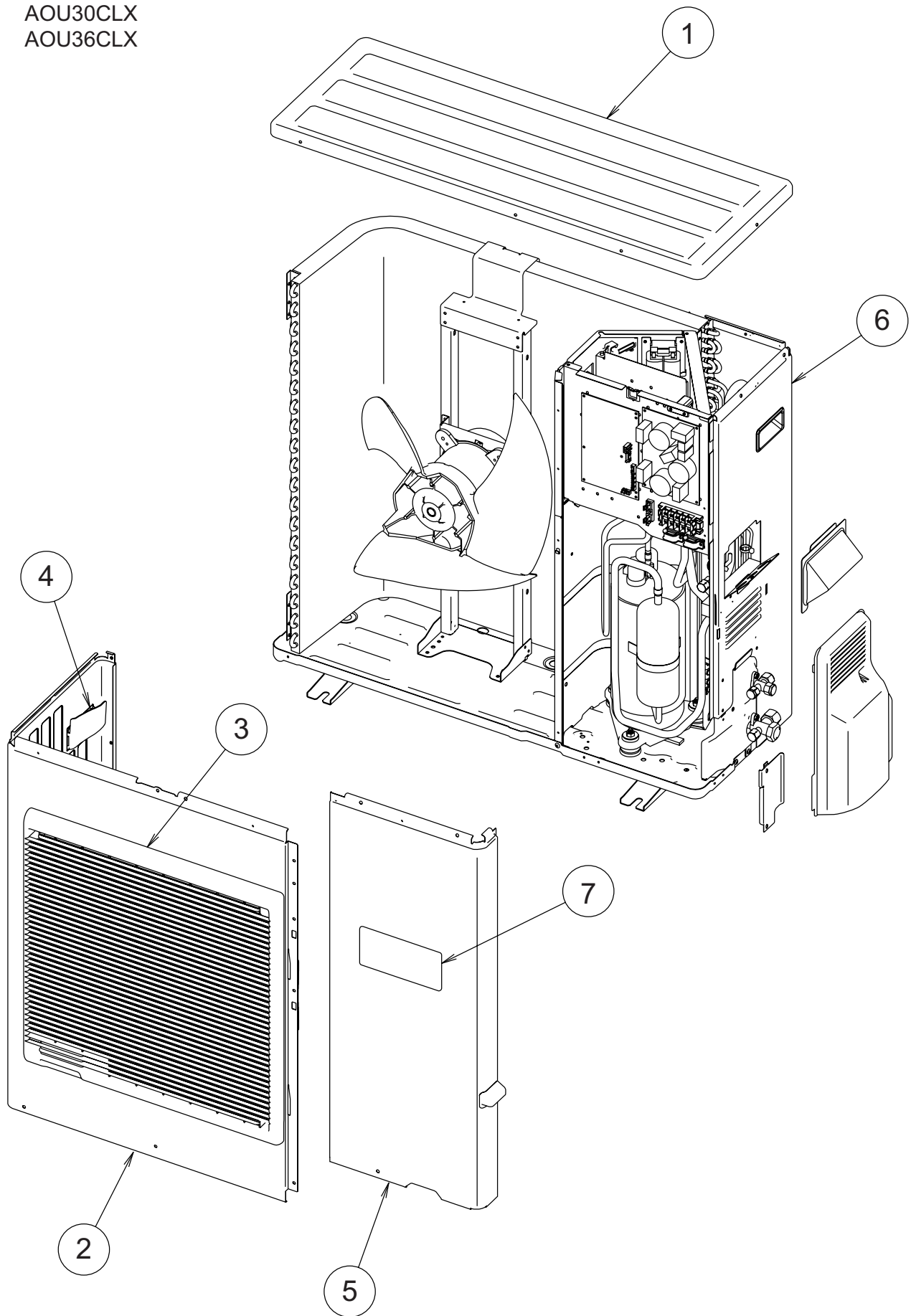

Models :
AOU30CLX
AOU36CLX

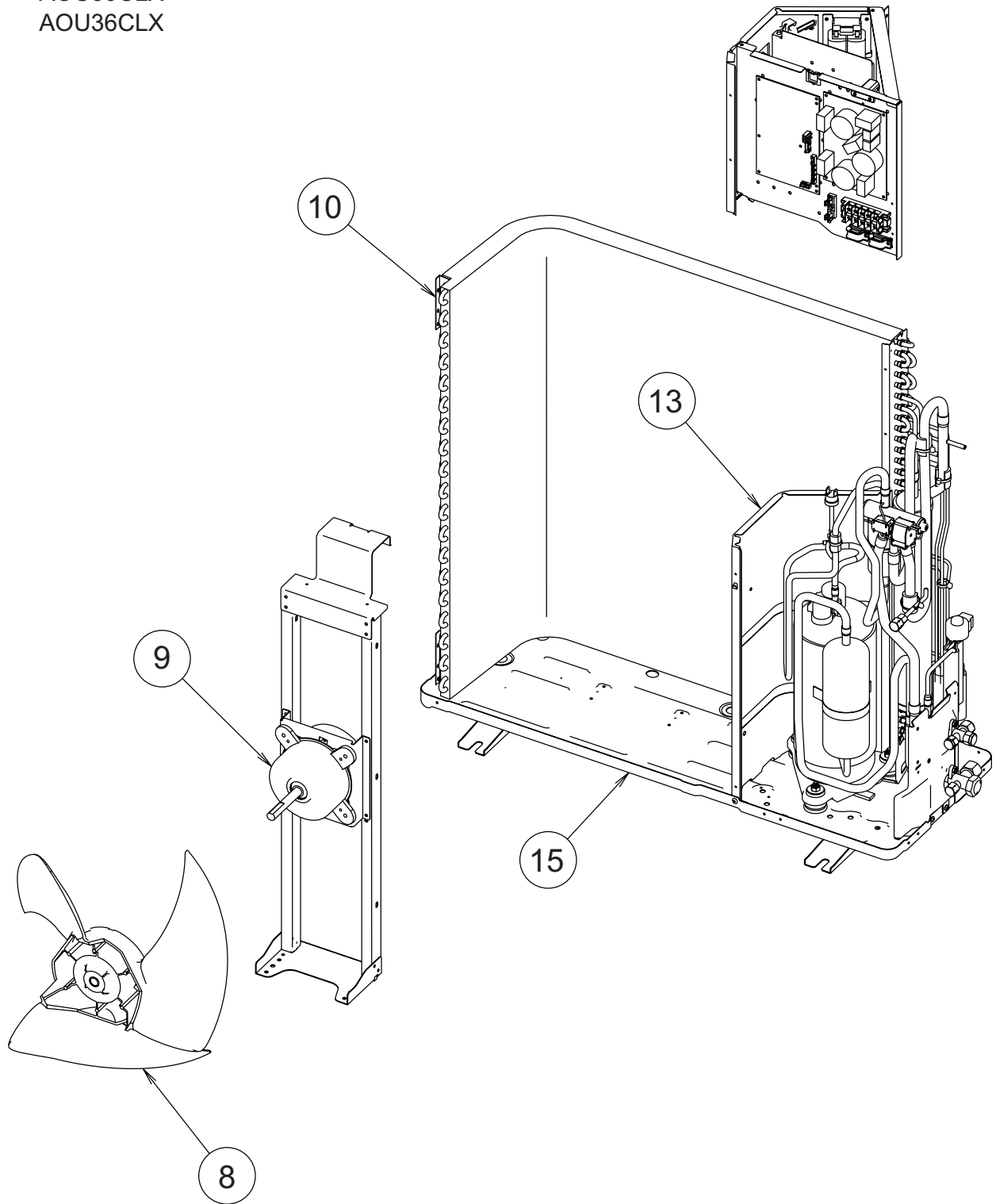

Models :
AOU30CLX
AOU36CLX

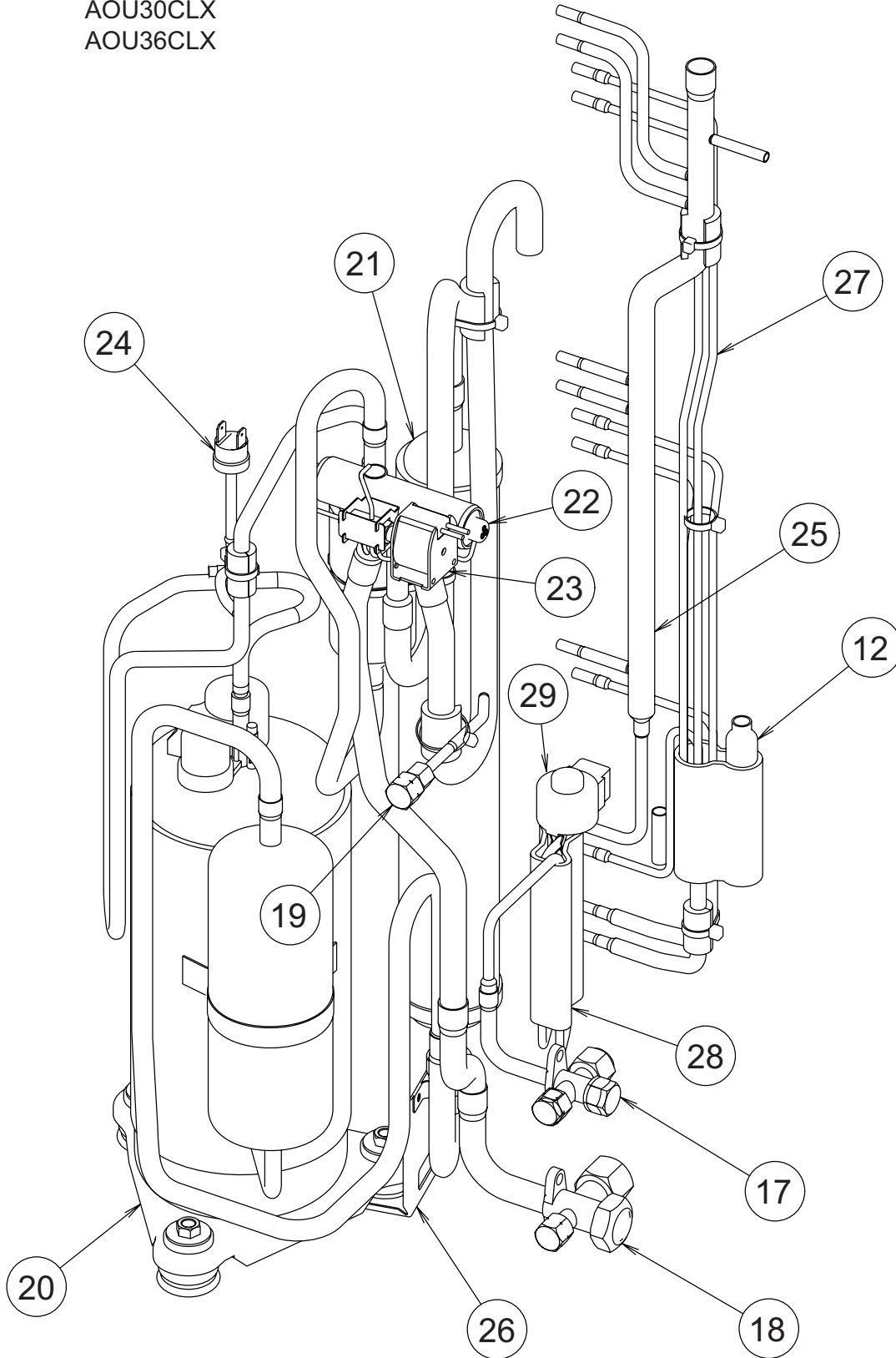

Models :
 AOU30CLX
 AOU36CLX

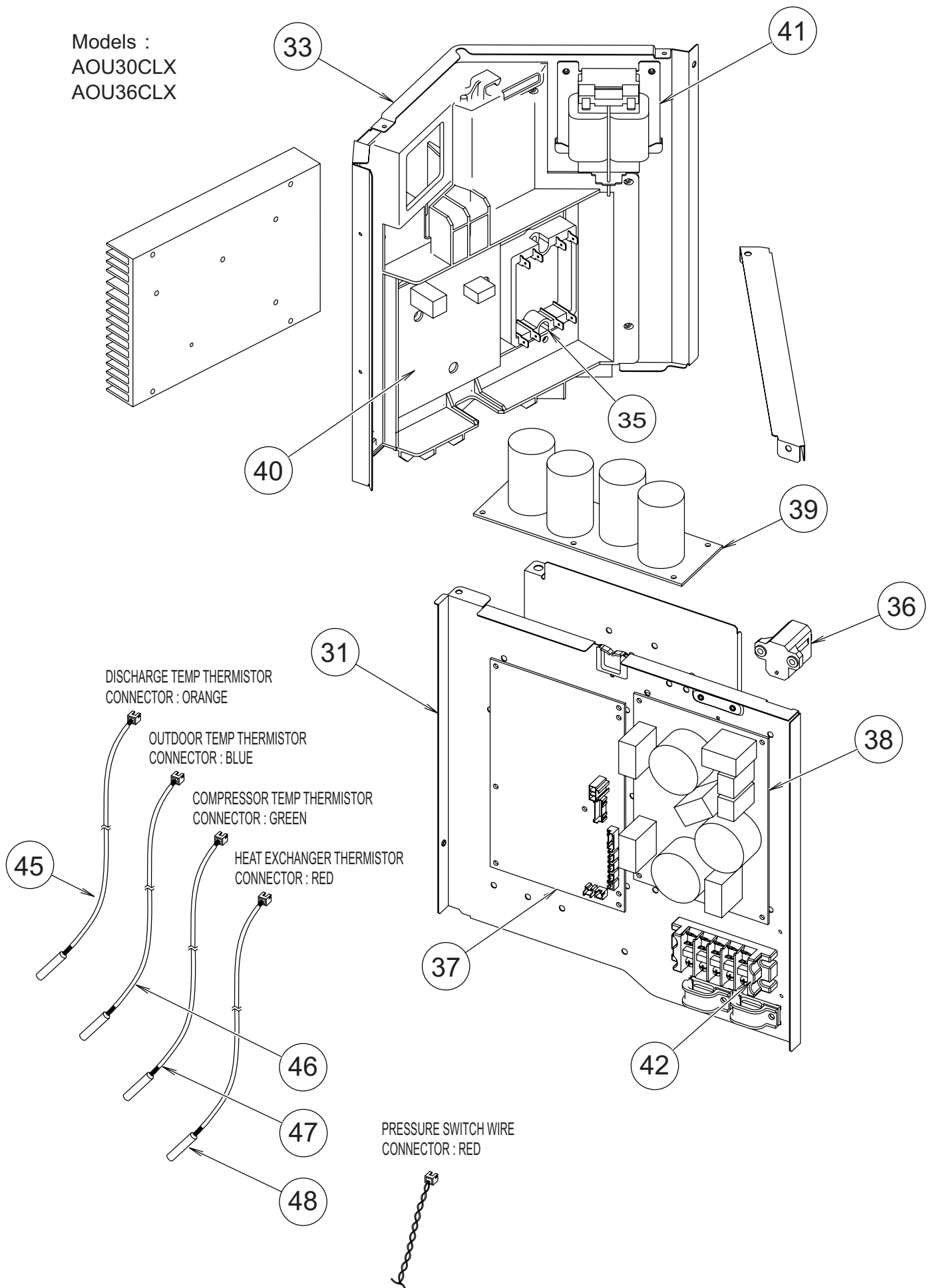

PARTS LIST







INDOOR UNIT

Ref. No.	Description	Part No.		Ord. Q'ty
		ASU30CLX	ASU36CLX	
1	Front Panel Total Assy	9315335036	9315335036	
2	Intake Grille Assy	9315336026	9315336026	
4	Air Filter	9315014016	9315014016	
5	Clamper (Grille)	9306755010	9306755010	
6	Receiver Window	9315010018	9315010018	
8	Crossflow Fan Assy	9315024015	9315024015	
9	Bearing C Assy	9306628017	9306628017	
10	Casing Assy	9315331021	9315331021	
11	Casing Cover B	9315016010	9315016010	
12	Casing Cover R	9315018014	9315018014	
13	Casing Cover L	9315017017	9315017017	
14	Casing Cover F	9315019011	9315019011	
15	Drain Hose Assy	9315769015	9315769015	
16	Bush B	9312156016	9312156016	
17	Diffuser U	9315002013	9315002013	
18	Diffuser Z	9315003010	9315003010	
19	Spring C	9314142017	9314142017	
20	Louver U	9315000019	9315000019	
21	Louver Z	9315001016	9315001016	
22	R and L Louver	9311997016	9311997016	
23	Spacer B	9312441013	9312441013	
25	Evaporator Assy C	9315789013	9315789013	
26	Drain Cap	9367677009	9367677009	
27	Evaporator Assy A	9315348012	9315348012	
28	Evaporator Assy B	9315349019	9315349019	
29	Connection Pipe Assy	9315355010	9315355010	
30	Distributor Assy	9315351012	9315351012	
31	Water Seal	9315251015	9315251015	
32	Evaporator Holder R	9314994012	9314994012	
33	Evaporator Holder L	9314995019	9314995019	
34	Rear Bracket	9315022011	9315022011	
35	Filter Guide	9315013019	9315013019	
36	Filter Guard	9315411013	9315411013	
37	Controller PCB Assy	9707090093	9707090109	
38	Control Box	9314996023	9314996023	
39	Control Cover	9314997020	9314997020	
40	Case (Motor)	9314998027	9314998027	
41	Terminal (Earth)	9315028013	9315028013	
42	Motor, DC Brushless	9602163014	9601924029	
46	Motor, Step	9900384029	9900384029	
47	Motor, Step	9900384036	9900384036	
48	Motor, Step	9900139063	9900139063	
52	Gear A	9309994003	9309994003	
53	Terminal	9900385019	9900385019	
55	Indicator PCB Assy	9707210019	9707210019	
56	Pipe Thermistor	9900389017	9900389017	
57	Room Thermistor	9700801108	9700801108	

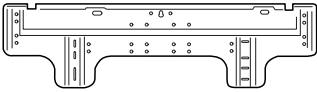
OUTDOOR UNIT

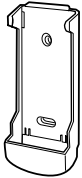
Ref. No.	Description	Part No.		Ord. Q'ty
		AOU30CLX	AOU36CLX	
1	Top Panel Sub Assy	9374417032	9374417032	
2	Front Panel	9374094066	9374094066	
3	Fan Guard	9374330010	9374330010	
4	Grip Side	9374173013	9374173013	
5	Service Panel Sub Assy	9374415052	9374415052	
6	Right Panel	9374095148	9374095148	
7	Emblem Rear	9351355005	9351355005	
8	Propeller Fan Assy	9366378020	9366378020	
9	Fan Motor, DC Brushless	9602114016	9602114016	
10	Condenser A Assy	9374433148	9374433148	
12	Strainer Assy	9372524015	9372524015	
13	Separate Wall	9374413133	9374413133	
15	Base Assy	9374166138	9374166138	
17	3-Way Valve Assy	9372205044	9372205044	
18	3-Way Valve Assy	9372205075	9372205075	
19	Check Joint Assy	9372802038	9372802038	
20	Compressor Assy	9372558126	9372558126	
21	Accumulator	9385005006	9385005006	
22	4-Way Valve	9900164010	9900164010	
23	Solenoid	9900165079	9900165079	
24	Pressure Switch	9900186012	9900186012	
25	Inlet Pipe (Cond) A Assy	9373461067	9373461067	
26	Accumulator Support Assy	313986353804	313986353804	
27	Outlet Pipe (Cond) A Assy	9374266104	9374266104	
28	Expansion Valve Assy	9370947144	9370947144	
29	Expansion Valve Coil	9900057039	9900057039	
31	Case (PCB) Assy	9375316013	9375316013	
33	Case (Inverter)	9375314019	9375314019	
35	ACTPM	9703457012	9703457012	
36	Thermistor	9704265012	9704265012	
37	Controller PCB Assy	9707121087	9707121094	
38	Power Supply PCB Assy (K05CW-0503HUE-FLO)	9707128086	9707128086	
39	Capacitor PCB Assy (K05FB-0500HUE-P0)	9707257014	9707257014	
40	TR PCB Assy (IPM)	9707125085	9707125085	
41	Choke Coil	9900366018	9900366018	
42	Terminal	9900203023	9900203023	
45	Discharge Temp Thermistor	9704219114	9704219114	
46	Thermistor (Outdoor Temp)	9900378028	9900378028	
47	Compressor Temp Thermistor	9900156022	9900156022	
48	Heat Exchanger Thermistor	9900374013	9900374013	

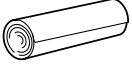
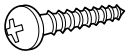
STANDARD ACCESSORIES

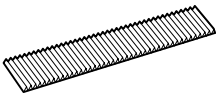
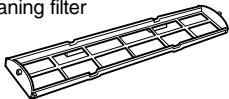
Name and Shape	Part No.
Wall hook bracket 	9315023018
Remote control unit 	9315027160
Remote control unit holder 	9305642045
Battery (penlight) 	0600185534
Cloth tape 	9310519004
Tapping screw (big) 	0700076046
Tapping screw (small) 	0700019036
Air cleaning filter 	9312153060
	9311925071
Air cleaning filter frame 	9368568009

Parts Orders

Parts maybe ordered from
FUJITSU GENERAL AMERICA, INC
353 RTE 46 W.

FAIRFIELD NJ 07004 PHONE 1-973-575-0380
FAX 1-973-575-2194

Specify complete Parts No., Model & Description to ensure
correct parts are supplied.

FUJITSU GENERAL AMERICA, INC.
353 ROUTE 46W., FAIRFIELD, N.J. 07004

0512G2975